

SERIA BVR

ŁYŻKI PRZESIEWAJĄCE

SCREENING BUCKET

PRZESIEWANIE I OCZYSZCZANIE
MATERIAŁÓW NATURALNYCH

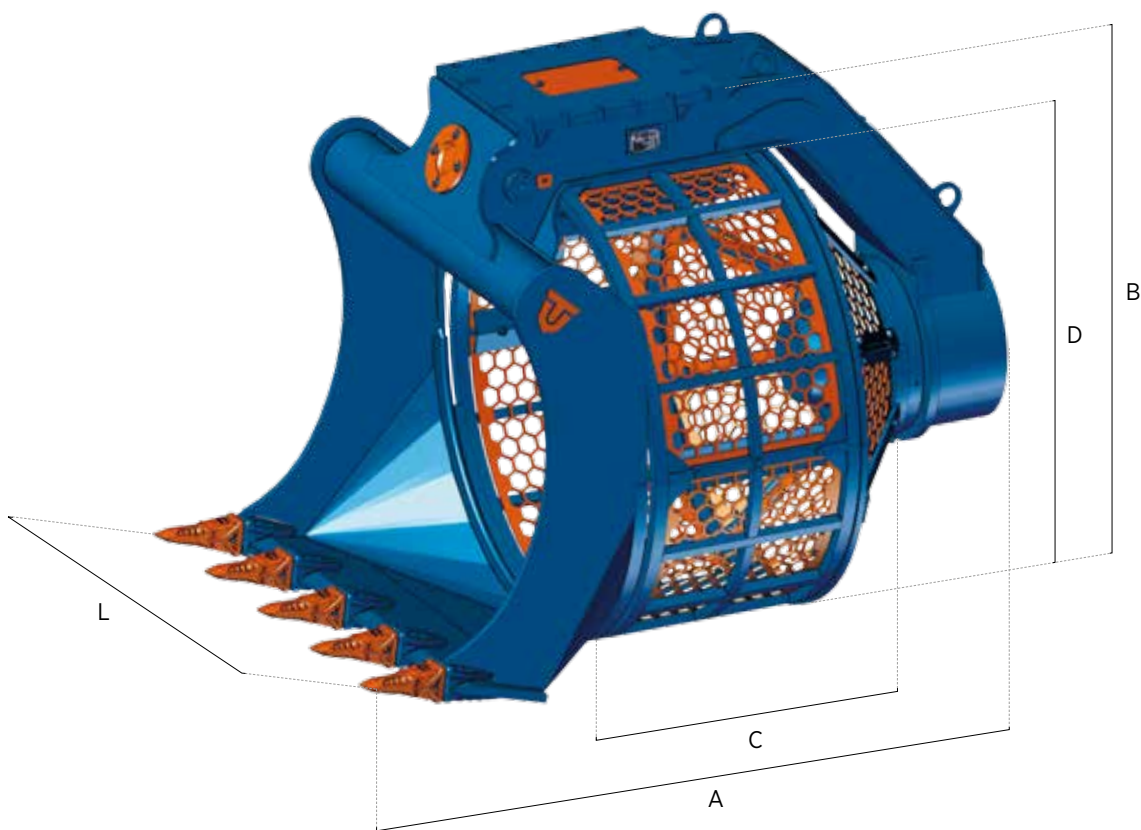





NEW



HARDOX®
WEAR PLATE

HARDOX®
IN MY BODY

		BVR 05	BVR 07	BVR 08
	kg.	110	250	350
A	mm.	740	1070	1175
B	mm.	630	805	930
C	mm.	320	445	515
D	mm.	500	640	750
L	mm.	520	700	800
Cap. SAE	m ³	0,2	0,3	0,5
	m ³	0,08	0,2	0,3
	bar	100 / 120	100 / 120	100 / 120
	l/min.	20 / 30	30 / 50	30 / 50
	rpm	24 / 32	18 / 24	18 / 24

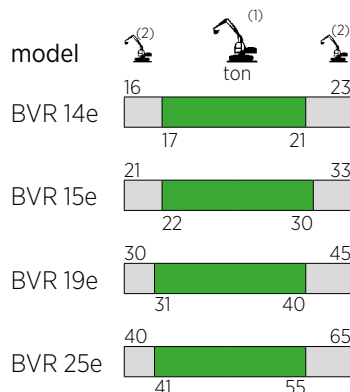
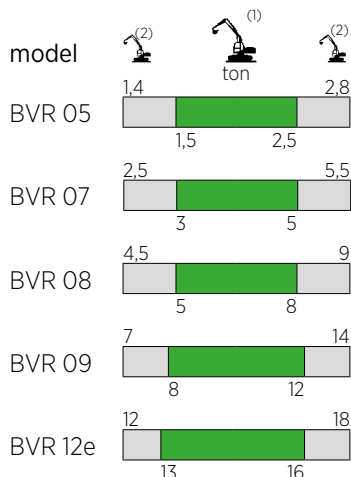

(1) Optimalna kombinacja koparka - osprzęt
Optimum excavator-equipment combination

(2) Możliwa kombinacja koparka - osprzęt
Possible excavator-equipment combination

NEW

		BVR 09	BVR 12e	BVR 14e	BVR 15e	BVR 19e	BVR 25e
	kg.	690	1320	1570	1810	2550	4900
A	mm.	1480	1950	2190	2250	2600	2950
B	mm.	1055	1460	1650	1890	2000	2410
C	mm.	690	790	925	980	1040	1360
D	mm.	840	1170	1340	1560	1700	2000
L	mm.	900	1200	1400	1600	1750	2120
Cap. SAE	m ³	0,7	1,3	1,7	2,1	2,8	5,3
	m ³	0,4	0,75	0,9	1,1	1,5	2,7
	bar	100 / 120	200 / 220	200 / 220	200 / 220	200 / 220	200 / 220
	l/min.	50 / 70	40 / 80	40 / 80	40 / 80	40 / 80	40 / 80
	rpm	18 / 24	18 / 35	18 / 35	18 / 35	18 / 35	18 / 27