

SERIA BM

ŁYŻKI KRUSZĄCE CRUSHING BUCKET

RECYKLING GRUZU BEZPOŚREDNIO
NA PLACU BUDOWY, KRUSZENIE SKAŁ
W KAMIENIOŁOMACH I KOPALNIACH

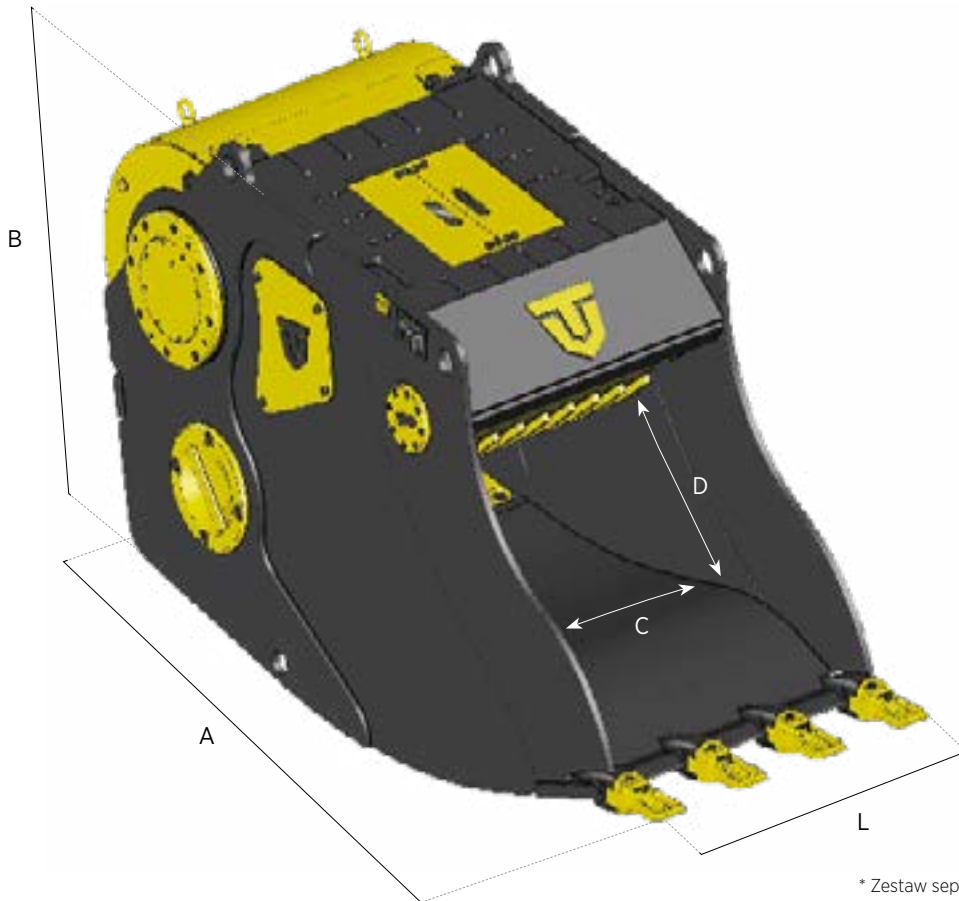

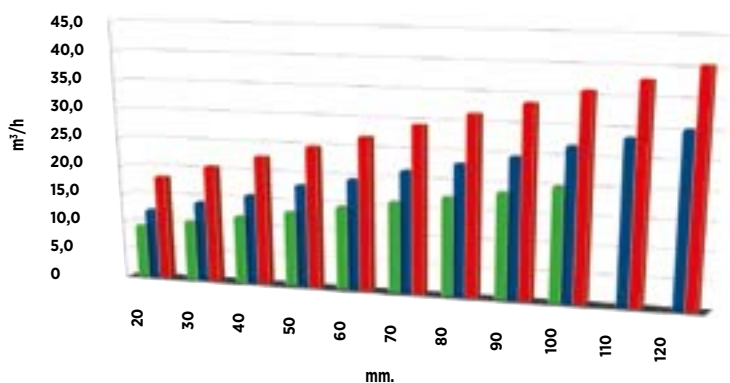

* Zestaw separatora magnetycznego zawiera: wsporniki, śruby, złącze elektryczne i okablowanie
* The magnetic separator kit contains: connecting brackets, screws and bolts, electrical connector and wiring

Wydajność względem wielkości materiału końcowego
Production of average toughness material

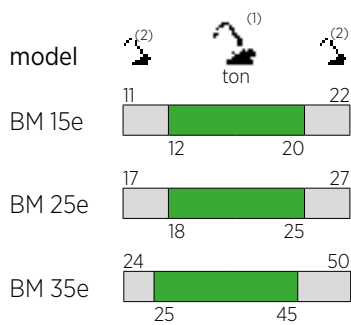

mm	BM 15e m³	BM 25e m³	BM 35e m³
20	9,3	12,2	18,3
30	10,5	14,0	20,5
40	11,9	15,8	22,7
50	13,2	18,0	24,8
60	14,6	19,5	26,9
70	15,9	21,4	29,3
80	17,3	23,1	31,5
90	18,6	24,7	33,6
100	20,0	26,8	35,9
110	/	28,5	38,0
120	/	30,2	40,5







-  (1) Optymalna kombinacja koparka - osprzęt
Optimum excavator-equipment combination
-  (2) Możliwa kombinacja koparka - osprzęt
Possible excavator-equipment combination



HARDOX
WEAR PLATE



		BM 15e	BM 25e	BM 35e
	kg.	1890	2680	3980
A	mm.	2030	2350	2805
B	mm.	1060	1220	1420
L	mm.	710	870	1050
C	mm.	650	775	980
D	mm.	500	590	660
Cap. SAE	m ³	0,45	0,55	0,95
	bar	220	220	220
	l/min.	150	180	180
	mm.	20 / 100	20 / 120	20 / 120
		√	√	√