

SERIA RC

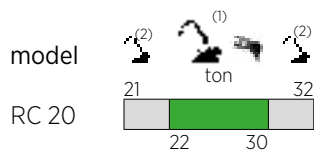

ŁAMACZ SZYN KOLEJOWYCH RAIL CROPPER

PEWNY CHWYT I PRECYZYJNE
ŁAMANIE SZYN KOLEJOWYCH

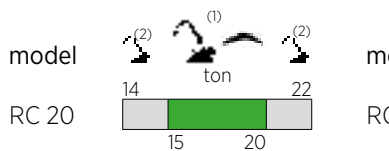
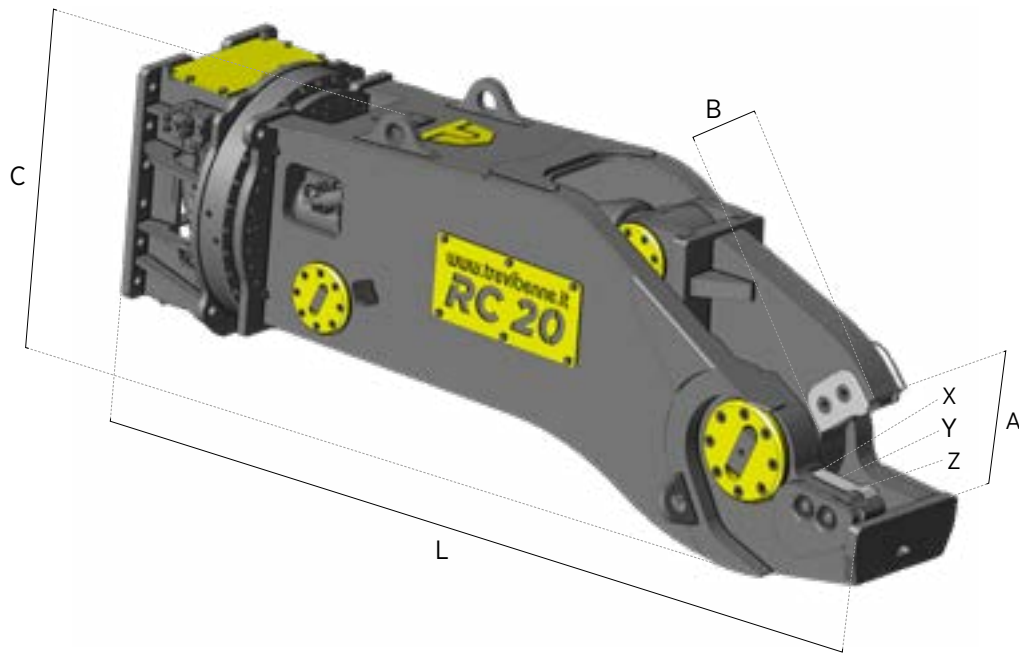

- (1) Optymalna kombinacja koparka - osprzęt
Optimum excavator-equipment combination
- (2) Możliwa kombinacja koparka - osprzęt
Possible excavator-equipment combination

		RC 20*
	kg.	2150
A	mm.	245
B	mm.	230
C	mm.	920
L	mm.	2500
X	t.	465
Y	t.	280
Z	t.	205
	bar	320
	l/min.	200 / 300
max	bar	140
max	l/min.	10

(*) Zawór bezpieczeństwa ustawiony na 250 bar / (*) Relief valve setted at 250 bar

