

# SERIA CS

## NOŻYCE DO CIĘCIA STALI

### MARILYN SHEARS

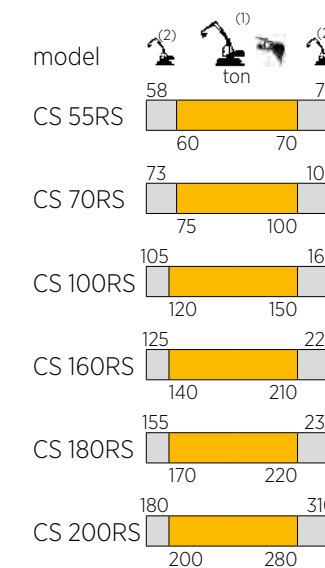
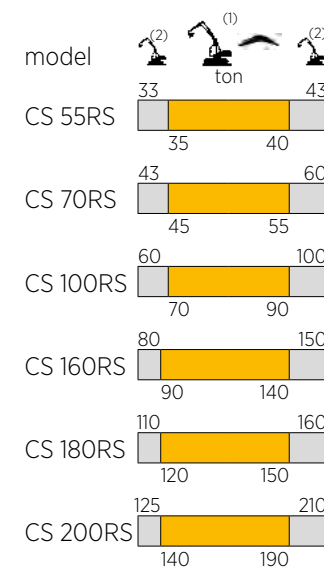
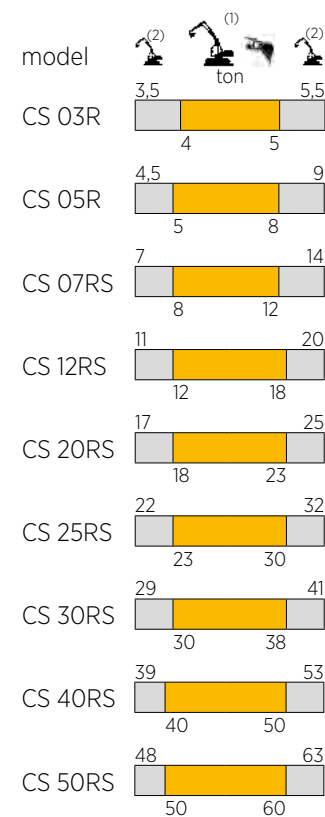
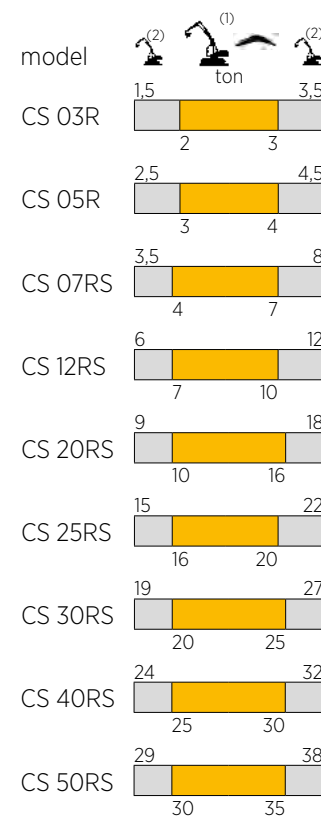
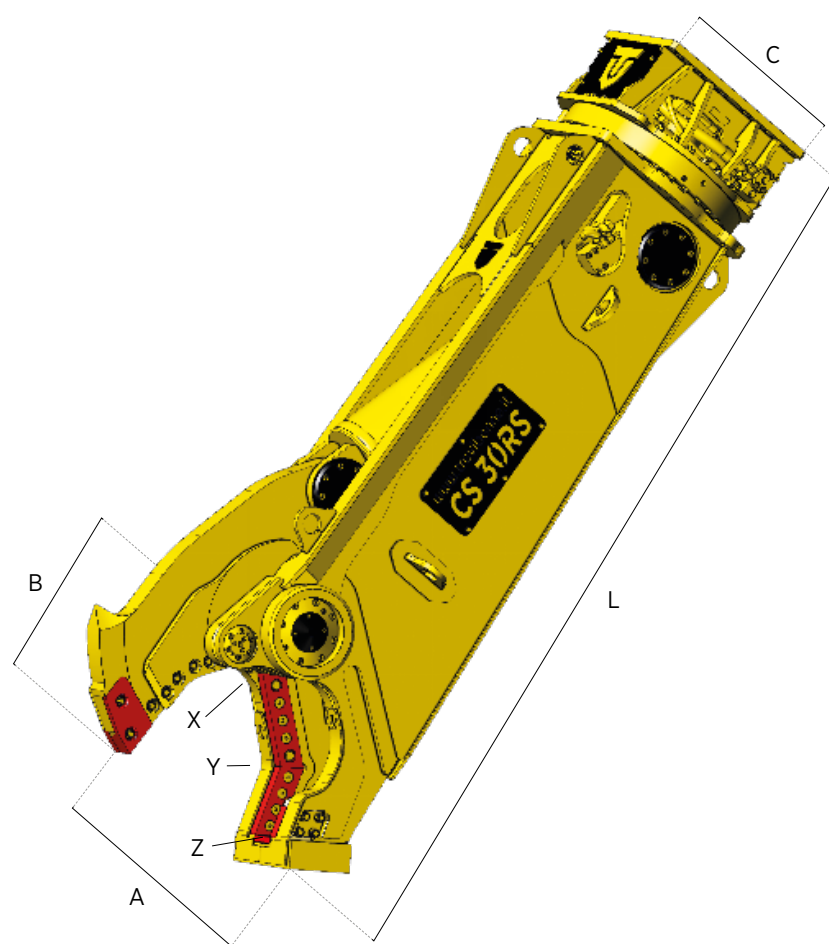

(1) Optymalna kombinacja koparka - osprzęt  
Optimum excavator-equipment combination

(2) Możliwa kombinacja koparka - osprzęt  
Possible excavator-equipment combination

		CS 03R	CS 05R	CS 07RS	CS 12RS	CS 20RS	CS 25RS	CS 30RS	CS 40RS	CS 50RS
📏	kg.	300	465	880	1180	2050	2650	3000	4030	4800
A	mm.	265	340	405	475	535	570	615	660	725
B	mm.	230	320	370	385	445	505	545	610	675
C	mm.	380	460	570	570	715	715	715	865	865
L	mm.	1330	1725	2180	2300	2660	2950	3130	3420	3660
X	t.	118	153	242	267	307	520	620	676	794
Y	t.	56	63	99	112	134	240	260	306	323
Z	t.	33	36	57	68	74	121	142	176	173
♀	max	bar	280	320	320	350	350	350	350	350
♂	l/min.	80 / 100	80 / 150	100 / 150	150 / 250	180 / 250	200 / 300	200 / 300	300 / 400	350 / 450
♀	max	bar	120	140	140	140	140	140	140	140
♂	l/min.	5	5	5	15 / 30*	20 / 40*	25 / 50*	25 / 50*	25 / 50*	25 / 50*
⚙️		/	/	/	/	/	/	/	/	√

\*Podwójny silnik / \*Double motor

		CS 55RS	CS 70RS	CS 100RS	CS 160RS	CS 180RS	CS 200RS
📏	kg.	6200	7900	10600	16700	17900	19500
A	mm.	780	845	930	1100	1100	1180
B	mm.	690	710	960	1080	1080	1130
C	mm.	1000	1100	1400	1325	1325	1750
L	mm.	3905	4190	4430	5440	5565	5580
X	t.	785	937	1186	1688	1688	1736
Y	t.	320	405	506	686	686	774
Z	t.	177	232	296	370	370	396
♀	max	bar	350	350	350	350	350
♂	l/min.	400 / 500	450 / 600	500 / 800	800 / 1000	800 / 1000	900 / 1200
♀	max	bar	140	140	140	250	250
♂	l/min.	25 / 50*	70	80	80	80	80
⚙️		√	√	√	√	√	√

\*Podwójny silnik / \*Double motor

UPDATED

