

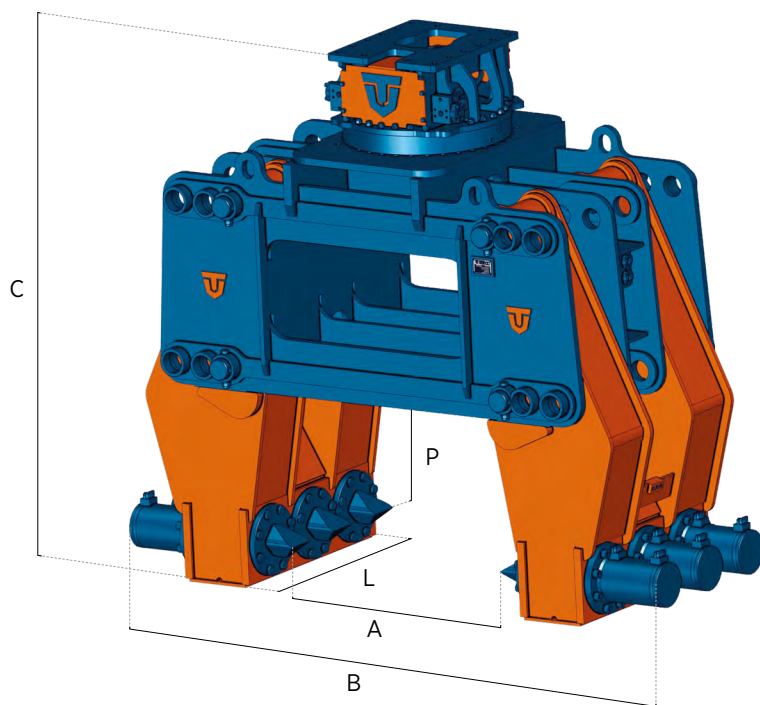

SERIA SC

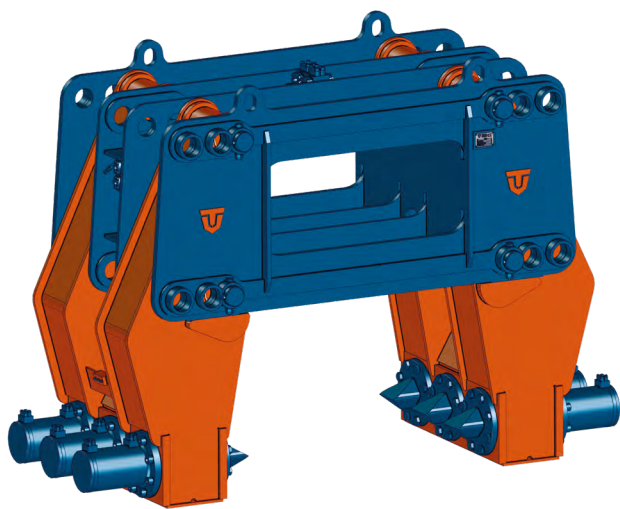

		SC 45	SC 45R*
	kg.	4650	5300
A	mm.	1000 / 1200 / 1500	1000 / 1200 / 1500
B	mm.	2650 / 2850 / 3150	2650 / 2850 / 3150
C	mm.	1900	2300
L	mm.	950	950
P	mm.	700	700
N°	n.	6	6
max	bar	350	350
	l/min.	200	200
max	bar	/	140
	l/min.	/	20 / 40**

*Modele z układem obrotowym 360° / *360° rotation model provided
 **Podwójny silnik / **Double motor

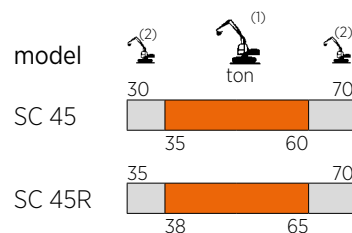

(1) Optymalna kombinacja koparka - osprzęt
 Optimum excavator - equipment combination

(2) Możliwa kombinacja koparka - osprzęt
 Possible excavator - equipment combination